

COMPACT[®] 26/3368RT

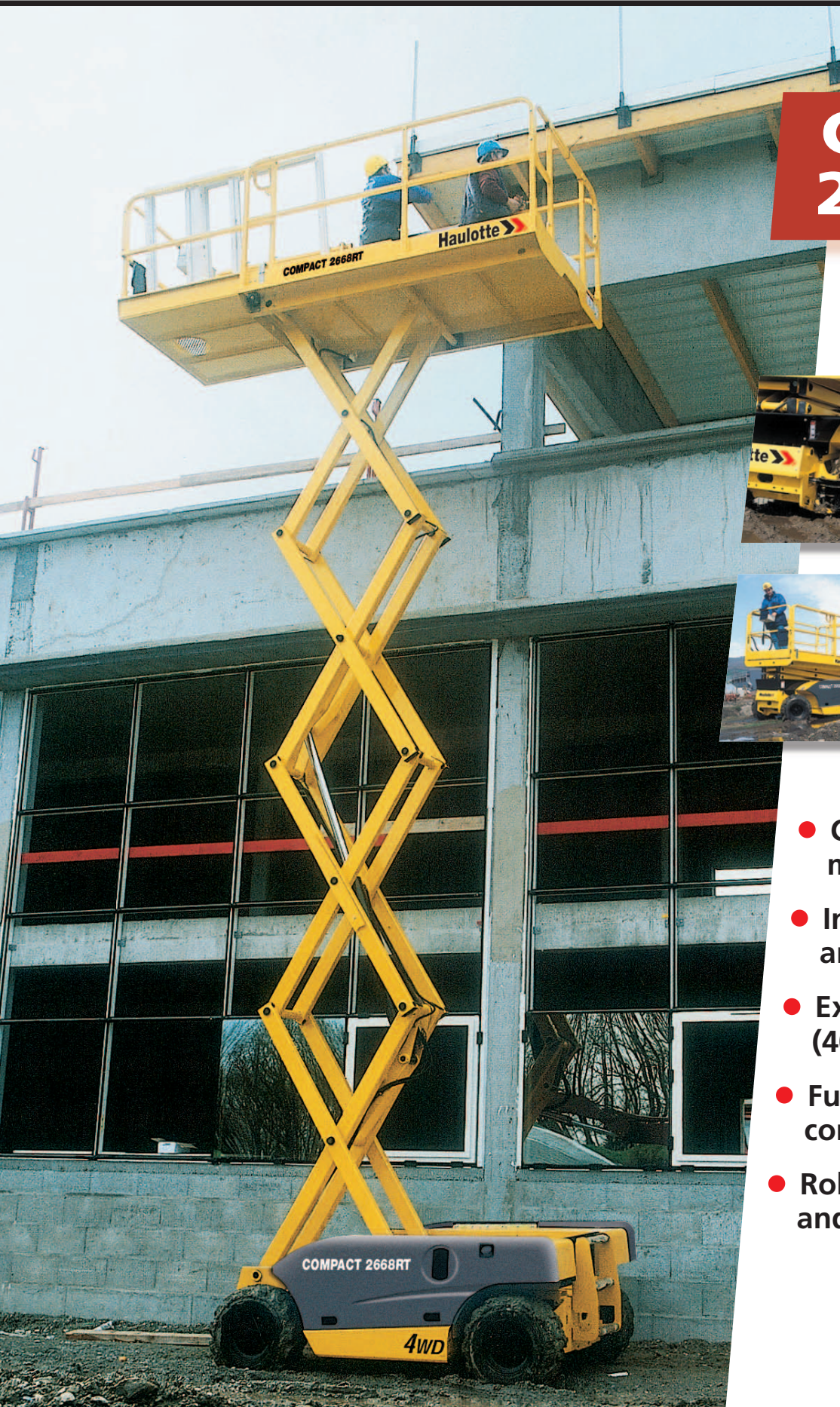

- Compact and manoeuvrable.
- Increased workspace area platform.
- Excellent gradeability (40%).
- Full proportional controls.
- Robust, reliable and easy to maintain.



COMPACT[®] 26/3368RT

Rough-terrain Scissor Lifts

STANDARD FEATURES

- Deutz engine
- 4 wheel drive and 2 front steering wheels
- Hydraulic differential lock
- Tilt alarm
- 47 in platform extension
- 12V - 70 Ah Batteries
- Removable operator's control box
- Free wheeling device
- Hourmeter
- Towing hooks / lifting eyes
- Hydraulic brakes
- Manual emergency lowering pull
- Foam filled all terrain tyres
- Side protections
- Horn
- Load limiter in cage with beep
- Removable control box
- Hooks for safety harness
- Driving proportional controls

OPTIONS & ACCESSORIES

- Individual levelling outriggers
- Rotating beacon
- Power line in cage
- Fall down handrails
- Automatic levelling outriggers
- Motion alarm
- Working light
- Catalytic exhaust
- Biodegradable oil
- Warming kit for engine oil

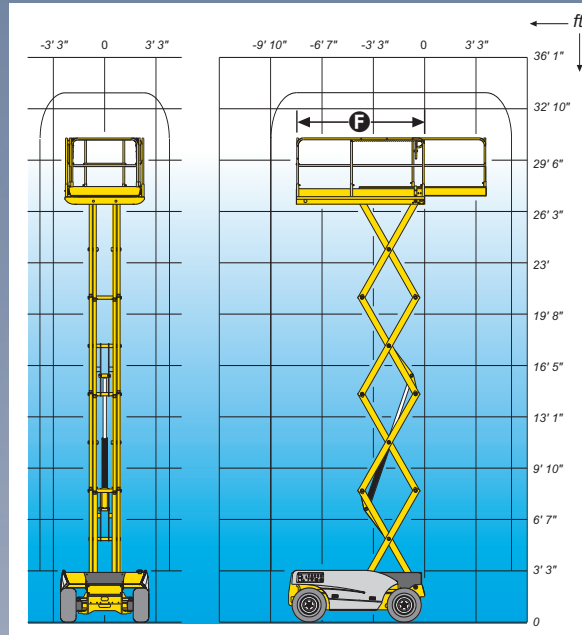
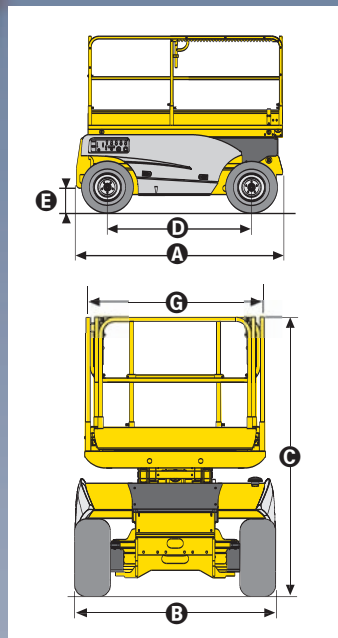

SPECIFICATIONS

	Compact 2668 RT	Compact 3368 RT
Working height	33 ft	39 ft 3 in
Platform height	27 ft	33 ft 3 in
Platform capacity	1,245 lb	992 lb
A Length	8 ft 8 in	
B Width	6 ft	
C Stowed height (guardrail)	7 ft 10 in	8 ft 4 in
Stowed height (platform)	4 ft 11 in	5 ft 6 in
D Wheelbase	6 ft 1 in	
E Ground clearance	10 in	
F x G Platform size	8 ft 2 in x 5 ft 1 in	
Platform extension	47 in	
Drive speed	0,5 / 3,4 mph	
Outside turning radius	12 ft 3 in	
Inside turning radius	4 ft	
Lift / lower speed (s)	31 / 27	45 / 39
Power source	Deutz 18 kW - 24.5 hp	
Gradeability	40%	
Brakes	Hydraulic	
Tyres (foam filled)	26 x 12 - 16.5	
Hydraulic tank	20 gal	
Fuel tank	8 gal	
Weight	7,300 lb	8,580 lb

ANSI/SIA A92.6 and CSA/B354.2 Standards Compliance



HAULOTTE us Inc - 7135 STANDARD DRIVE - HANOVER MD 21076 - USA
 PHONE : +1 410 712 4403 - FAX : +1 410 712 4419
 Main Toll Free : +1 877-HAULOTTE - e-mail : sales@us.haulotte.com

Haulotte Group - La Péronnière - BP 9 -42152 l'Horme - France

Tél : +33 (0)4 77 29 24 24 - Fax : +33 (0)4 77 29 43 95 - e-mail : haulotte@haulotte.com - web : http://www.haulotte.com

