

HA 61JRT



- +70° / - 70° fly jib
- 44 ft 3 in horizontal outreach
- Standard 4 wheel drive and 4 wheel steer
- 507 lb platform capacity
- 40% gradeability



HA 61JRT

Articulating Boom

The Haulotte® advantages

- Improved working area and visibility through a positive / negative articulating fly jib with 140° movement
- 12 ft 9 in turning radius for improved manoeuvrability
- Hydraulic differential lock and 17 in ground clearance for improved rough terrain capability
- Continuous 360° turntable rotation
- 180° hydraulic platform rotation
- Compact travel/transport dimensions
- Full proportional controls and simultaneous boom functions improve productivity
- Robust, reliable and easy to maintain

STANDARD FEATURES

- 4 wheel drive and 4 wheel steer
- Tilt alarm
- Deutz Diesel 57.1 hp - 42 kW
- 110 V outlet
- 12 V - 105 Ah - 720 A battery / electrical control system
- Free wheeling device
- Battery emergency lowering system
- Safe use in winds up to 28 mph
- Hourmeter
- Slewing block pin
- Towing hooks / lifting brackets

OPTIONS & ACCESSORIES

- Rotating beacon
- Flashing light
- Travel alarm
- Catalytic purifier
- Overload device
- Generator 3 kW
- 8 ft basket
- 550 lb Platform Capacity with 37 mph wind.

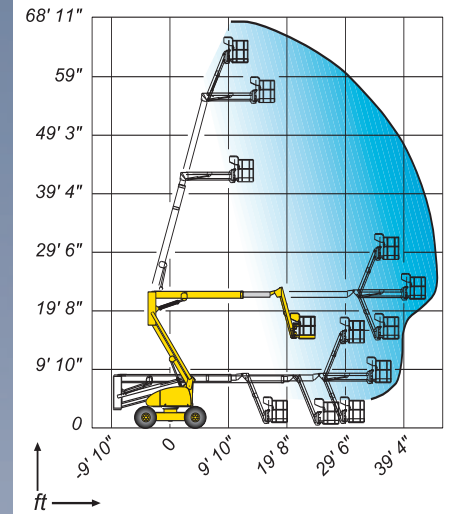
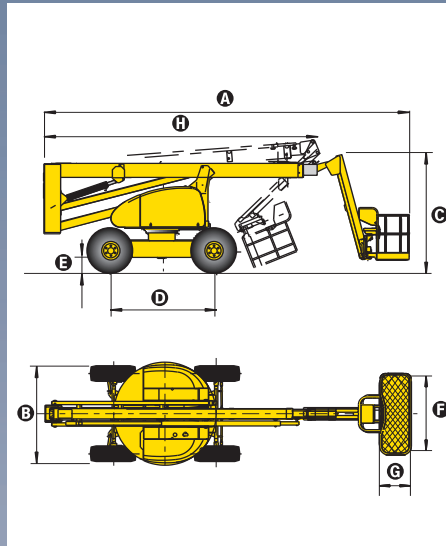

SPECIFICATIONS

Working Height	67 ft 2 in
Platform Height	61 ft 2 in
Horizontal outreach	44 ft 3 in
Up and Over height	22 ft 3 in
Platform Capacity	507 lb
Fly jib range of motion	140° (+70° / -70°)
A Length	29 ft 6 in
B Width	7 ft 8 in
C Stowed Height	8 ft 9 in
D Wheelbase	9 ft 2 in
E Ground clearance	17 in
F x G Platform size	71 in x 32 in
H Travel/transport length	22 ft 4 in
Tailswing	0
Drive speed	0.6 - 2.8 mph
Outside turning radius	12 ft 9 in
Turntable Rotation (continuous)	360°
Hydraulic platform rotation	180°
Gradeability	40%
Engine	Deutz Diesel 57.1 hp - 42 kW
Controls	Proportional
Tires (Foam Filled)	15 R
Hydraulic tank	40 gal
Fuel tank	40 gal
Weight	25,821 lb

ANSI/SIA A92.5 and CSA/B354.4 Standards Compliance



HAULOTTE us Inc - 7135 STANDARD DRIVE - HANOVER MD 21076 - USA
 PHONE : +1 410 712 4403 - FAX : +1 410 712 4419
 Main Toll Free : +1 877-HAULOTTE - e-mail : sales@us.haulotte.com

Haulotte Group - La Péronnière - BP 9 -42152 l'Horme - France

Tél : +33 (0)4 77 29 24 24 - Fax : +33 (0)4 77 29 43 95 - e-mail : haulotte@haulotte.com - web : http://www.haulotte.com

Haulotte 
 GROUP