

HB 40 HB 44 J



- 34 ft 9 in and 40 ft 4 in horizontal outreach.
- 507 lb platform capacity.
- Standard 4 wheel drive.
- 13 in ground clearance.



HB 40 HB 44 J

Telescopic booms

The Haulotte® advantages

- Hydraulic differential lock, standard 4 wheel drive, 13 in ground clearance improve rough terrain capability
- HB 44J : improved working area through a positive / negative articulating fly jib with 140° movement (-70°/+70°)
- Continuous 360° turntable rotation
- 180° hydraulic platform rotation
- Compact travel / transport dimensions
- Full proportional controls and simultaneous boom functions improve productivity
- Robust, reliable and easy to maintain design

STANDARD FEATURES

- Deutz diesel engine
- 4 wheel drive
- Tilt alarm
- 12 V electrical control system
- 12 V – 95 Ah – 450 A battery
- Free wheeling device
- Battery emergency lowering system
- Hourmeter
- Slewing block pin
- Towing hooks / lifting brackets
- 110 V outlet

OPTIONS & ACCESSORIES

- HB 44J : 8' platform
- Rotating beacon
- Work light
- Travel alarm
- Overload device
- Generator 3 kW
- Dual fuel engine, GM 1.6 L - 41hp (30.6 kW)

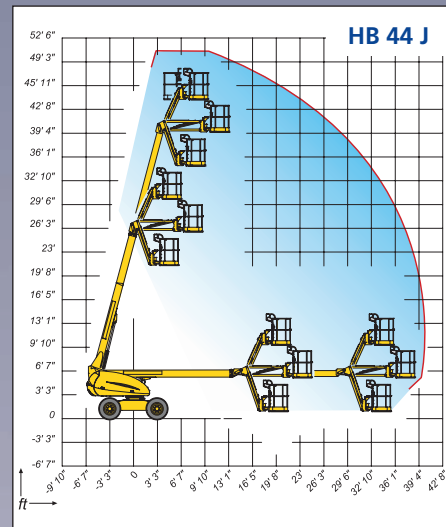
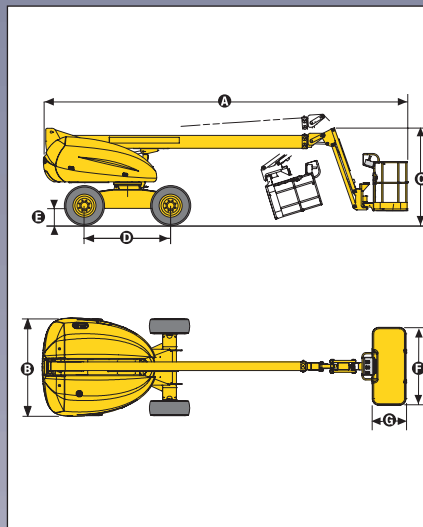

SPECIFICATIONS

	HB 40	HB 44 J
Working Height	45 ft 4 in	50 ft 1 in
Platform Height	39 ft 4 in	44 ft 1 in
Horizontal outreach	34 ft 9 in	40 ft 4 in
Platform capacity	507 lb	507 lb
Fly jib range of motion	N/A	140° (+70°/-70°)
Jib length	N/A	4 ft 11 in
A Length	24 ft 10 in	27 ft 8 in
B Width	7 ft 6 in	7 ft 6 in
C Stowed Height	7 ft 2 in	7 ft 3 in
D Wheelbase	6 ft 7 in	6 ft 7 in
E Ground Clearance	13 in	13 in
F x G Platform size	71 in x 32 in	71 in x 32 in
Travel / Transport length	24 ft 10 in	22 ft
Travel / Transport height	7 ft 2 in	8 ft 3 in
Tailswing	32 in	32 in
Drive speed	3.1 mph	3.1 mph
Outside turning radius (wheel)	14 ft 1 in	14 ft 1 in
Turntable rotation (continuous)	360°	360°
Hydraulic platform rotation	180°	180°
Engine	Deutz Diesel 31 kW / 42 hp	
Controls	Proportional	
Gradeability	50%	
Tires (Foam Filled)	SKS Hauler 14 - 17.5	
Hydraulic tank	40 gal.	40 gal.
Fuel tank	40 gal.	40 gal.
Weight	13,316 lb	14,550 lb

ANSI/SIA A92.5 and CSA/B354-4 Standards Compliance



Haulotte 
GROUP

HAULOTTE US INC • 7135 Standard drive - Hanover - MD21076 - USA
Tel : +1 410 7124403 • Fax : +1 410 7124419 • Toll free : +1 877-HAULOTTE • e-mail : sales@us.haulotte.com

Haulotte Group - La Péronnière - BP 9 - 42152 l'Horme - France • Tél : +33 (0)4 77 29 24 24 - Fax : +33 (0)4 77 29 43 95
e.mail - haulotte@haulotte.com • web : http://www.haulotte.com