

## HA 100 JRT



- Max. 69 ft 11 in horizontal outreach.
- 37 ft 3 in up and over clearance
- Standard 4 wheel drive and steer.
- 15 in ground clearance.
- Hydraulic differential lock.
- Extendable axles.



## The Haulotte® advantages

- 104 ft working height
- 37 ft 3 in up and over clearance
- Hydraulic differential lock and 15 in ground clearance for improved rough terrain capability
- Gradeability up to 45%
- Continuous 360° turntable rotation
- Full proportional controls and simultaneous boom functions improve functionality
- Improved working area through a positive/negative articulating fly jib with 140° movement
- 180° hydraulic platform rotation
- Robust, reliable and easy to maintain design

## STANDARD FEATURES

- 4 wheel drive and 4 wheel steer
- 2 extending axles
- Oscillating axle
- 115 V - 15 A power line from chassis to platform
- Rotating engine tray for easier maintenance
- Tilt alarm
- 12 V battery / electrical control system
- Electric emergency group in cage
- Free wheeling device
- Hourmeter
- Chassis rotation lock pin
- Towing hooks / lifting eyes
- Safe use in winds up to 37mph

## OPTIONS & ACCESSORIES

- On-board 3 300 W generator
- Travel alarm
- Rotating beacon
- Working light
- Catalytic exhaust purifier

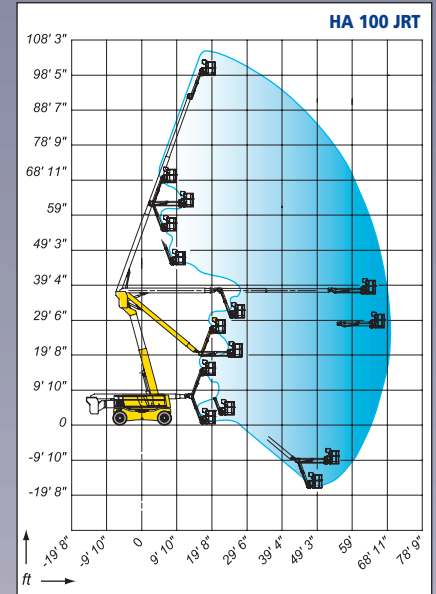
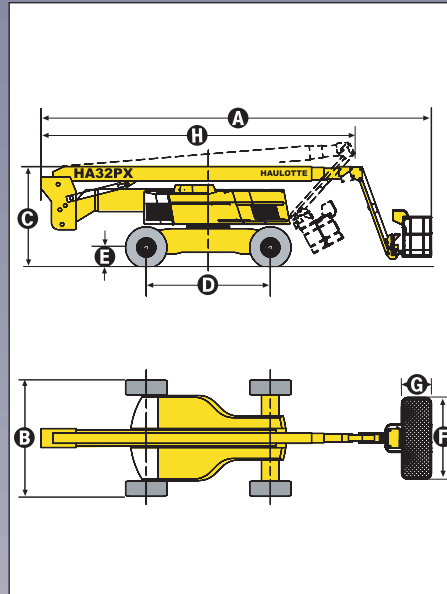

## SPECIFICATIONS

	HA 100 JRT
Working height	103 ft 9 in
Platform height	97 ft 9 in
Maximum outreach	69 ft 11 in
Up and over clearance	37 ft 3 in
Platform capacity	551 lb
Fly jib range of motion	140° (+70° / -70°)
<b>A</b> Length	36 ft 7 in
<b>B</b> Width	8 ft 2 in
Width (with extended axles)	10 ft 11 in
<b>C</b> Stowed height	8 ft 10 in
<b>D</b> Wheelbase	11 ft 6 in
<b>E</b> Ground clearance	15 in
<b>F</b> X <b>G</b> Platform size	96 in x 32 in
<b>H</b> Travel / transport length	29 ft 2 in
Travel / transport height	10 ft 10 in
Tailswing	1 ft 8 in
Drive speed	3.1 mph
Outside turning radius	16 ft 8 in
Turntable rotation (continuous)	360°
Hydraulic platform rotation	180°
Engine	Perkins Diesel - 64 kW - 87 hp
Gradeability	45%
Tires (foam filled)	445 / 65 - 22.5
Hydraulic tank	52 gal.
Fuel tank	37 gal.
Weight	46,118 lb

ANSI/SIA A92.5 and CSA/B354-4 Standards Compliance

