

HB 68J HB 76J



- +70° / -70° fly jib
- Standard 4 wheel drive
- 507 lb platform capacity
- 13 in ground clearance



HB 68J HB 76J

Telescopic Booms

The Haulotte® advantages

- Improved working area and visibility through a positive / negative articulating fly jib with 140° movement
- Hydraulic differential lock and 14 in ground clearance for improved rough terrain capability
- Continuous 360° turntable rotation
- 180° hydraulic platform rotation
- Compact travel / transport dimensions
- Full proportional controls and simultaneous boom functions improve productivity
- Robust, reliable and easy to maintain

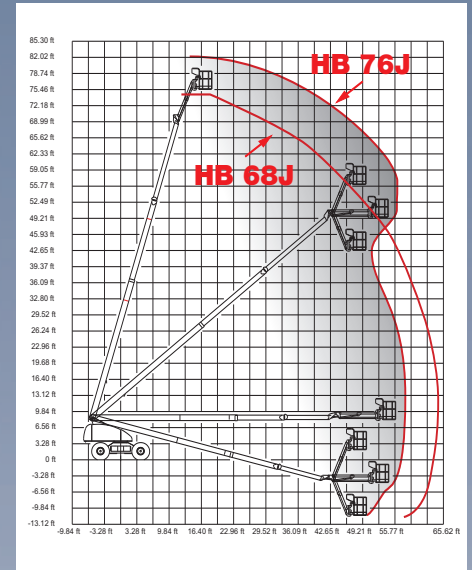
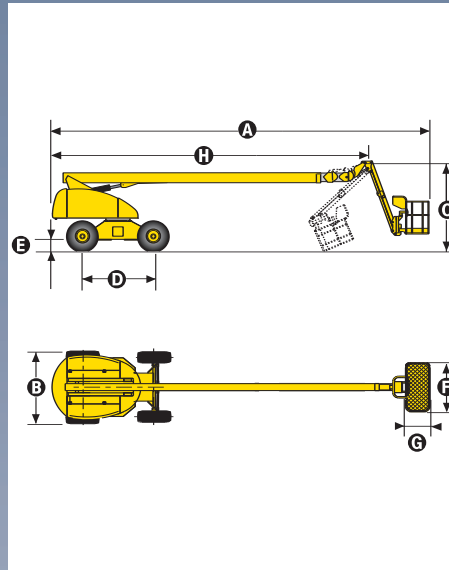

STANDARD FEATURES

- Silent pack Hatz Diesel engine
- 4 wheel drive
- Tilt alarm
- 12 V electrical control system
- 12 V - 95 AH battery
- Free wheeling device
- Battery emergency lowering system
- Safe use in winds up to 28 mph
- Hourmeter
- Slewing block pin
- Towing hooks / lifting brackets
- 110 V outlet

OPTIONS & ACCESSORIES

- Rotating beacon
- Flashing light
- Travel alarm
- Catalytic exhaust
- Overload device
- Generator 3 kW
- HB 68 J : 551 lb Platform Capacity with 37 mph wind. (Machine weight : 20,076 lb)
- HB 68 J : 91 in x 32 in platform

SPECIFICATIONS

	HB 68J	HB 76J
Working height	73 ft 7 in	82 ft 5 in
Platform height	67 ft 7 in	76 ft 5 in
Horizontal outreach	64 ft 2 in	57 ft 1 in
Platform capacity	507 lb	
Fly jib range of motion	140° (+70°/-70°)	
Jib length	7 ft 2 in	
A Length	34 ft 9 in	43 ft
B Width	8 ft 1 in	
C Stowed height	9 ft 10 in	
D Wheelbase	8 ft 2 in	
E Ground clearance	13 in	
F x G Platform size	71 in x 32 in	
H Travel/transport length	26 ft 7 in	35 ft 5 in
Tailswing	42 in	
Drive speed	0.9 - 3.1 mph	
Outside turning radius	20 ft 2 in	
Turntable rotation (continuous)	360°	
Hydraulic platform rotation	180°	
Gradeability	40%	
Engine	Diesel 43.6 hp / 32.1 kW	
Controls	Proportional	
Tires (foam filled)	15 R 22	
Hydraulic tank	40 gal	
Fuel tank	40 gal	
Weight	28,908 lb	30,253 lb

ANSI/SIA A92.5 and CSA/B354.4 Standards Compliance



HAULOTTE us Inc - 7135 STANDARD DRIVE - HANOVER MD 21076 - USA
PHONE : +1 410 712 4403 - FAX : +1 410 712 4419
Main Toll Free : +1 877-HAULOTTE - e-mail : sales@us.haulotte.com

Haulotte Group - La Péronnière - BP 9 -42152 l'Horme - France

Tél : +33 (0)4 77 29 24 24 - Fax : +33 (0)4 77 29 43 95 - e-mail : haulotte@haulotte.com - web : http://www.haulotte.com

