

ROUGH-TERRAIN SCISSOR LIFTS

HS 3388 RT
HS 4388 RT
HS 5388 RT



- 1,984 lb lift capacity (HS 3388RT)
 - 19 ft 5 in x 5 ft 10 in platform*
 - 40% gradeability
 - Standard 4 wheel drive
- *with twin extension decks



HS 3388 RT
HS 4388 RT
HS 5388 RT

Rough-terrain Scissor Lifts

The Haulotte® advantages

- Low stowed platform height for easy access
- Foam filled tires standard
- Twin extension decks for increased workspace
- Hydraulic differential lock for improved rough terrain capability
- Robust, reliable and easy to maintain

STANDARD FEATURES

- 4 wheel drive
- Hatz silent pack diesel engine
- Full proportional controls
- Tilt alarm
- 11 in ground clearance for improved rough terrain performance
- 3.7 mph travel speed
- Narrow turning radius for better manoeuvrability.
- Removable operator's control box
- Free wheeling device
- Hourmeter
- Towing hooks
- Hydraulic brakes
- Emergency lowering system
- Twin 3 ft 3 in sliding deck
- 110 V outlet

OPTIONS & ACCESSORIES

- Automatic hydraulic levelling jacks (Standard on HS 5388RT)
- Catalytic exhaust
- Rotating beacon
- Travel alarm
- Work light
- Overload device
- Mains power outlet on platform
- Encoded starting device
- Biodegradable hydraulic oil
- Motion alarm for movements and translation
- Non-marking tires
- Cold weather kit
- Hot weather kit
- Dual fuel engine, GM 1.6 L - 41hp (30.6 kW)
- 3 kW Generator

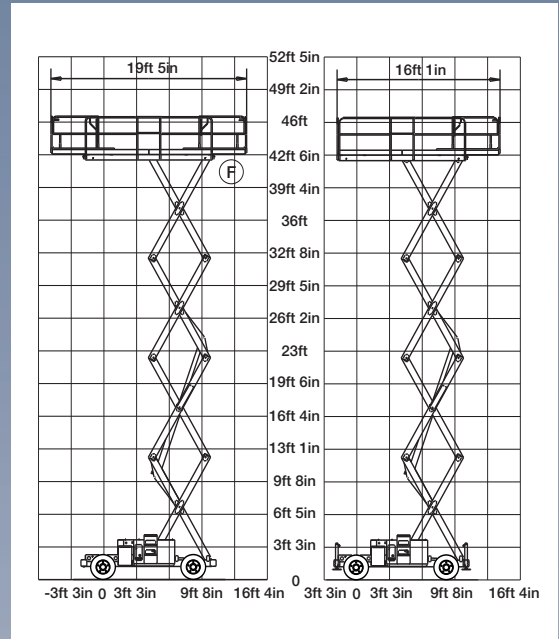
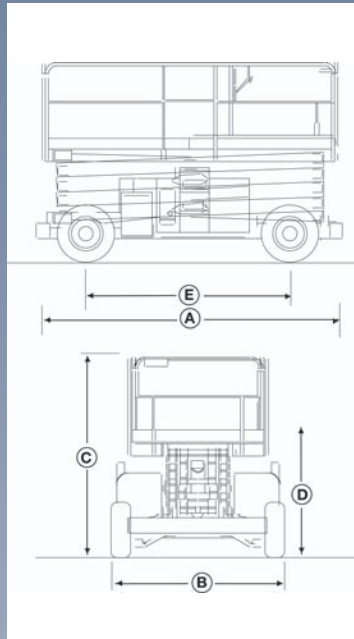

SPECIFICATIONS

	HS 3388RT	HS 4388RT	HS 5388RT
Working Height	38 ft 9 in	48 ft 7 in	58 ft 5 in
Platform Height	32 ft 9 in	42 ft 7 in	52 ft 5 in
Platform Capacity *	1,984 lb	1,543 lb	1,323 lb
A Length	13 ft 6 in		
B Width	88 in		
C Stowed Height (guardrail)	8 ft 5 in	9 ft	9 ft 8 in
D Stowed Height (platform)	4 ft 6 in	5 ft 2 in	5 ft 10 in
E Wheelbase	9 ft		
Platform size	194 in x 71 in		
F Platform extension	3 ft 3 in		
Drive speed	0.4 / 3.7 mph		
Outside turning radius	16 ft 3 in		
Ground clearance	11 in		
Power source	Diesel 32 hp (23.6 kw)		
Gradeability	40%		
Raise / Lower speed	43 / 65 sec.	46 / 57 sec.	60 / 60 sec.
Drive	Dual front wheel		
Tires (Foam Filled)	10 x 16.5		
Hydraulic tank	26 gal		
Fuel tank	17 gal		
Weight	11,600 lb	13,560 lb	15,970 lb

ANSI/SIA A92.6 and CSA/B354.2 Standards Compliance

* with single deck extension



HAULOTTE us Inc - 7135 STANDARD DRIVE - HANOVER MD 21076 - USA
 PHONE : +1 410 712 4403 - FAX : +1 410 712 4419
 Main Toll Free : +1 877-HAULOTTE - e-mail : sales@us.haulotte.com

Haulotte Group - La Péronnière - BP 9 -42152 l'Horme - France

Tél : +33 (0)4 77 29 24 24 - Fax : +33 (0)4 77 29 43 95 - e-mail : haulotte@haulotte.com - web : http://www.haulotte.com

