

STAR 22J STAR 26J



- 9 ft 10 in outreach.
- Compact: 345°. Rotation with zero tail swing.
- 441 lb platform capacity.
- Proportional electric controls.
- High autonomy.
- Internal and external use



STAR 22J STAR 26J

Vertical masts

The Haulotte® advantages

- Full electric drive with the ability to drive at full height
- Proportional controls provide for smooth and progressive movements
- Narrow turning radius for better accessibility
- Increased safety with 3° slope sensor and pot hole protection
- The positive/negative jib offers more flexibility throughout the working envelope
- 2.8 mph travel speed
- 23% gradeability
- Low total weight for easier transport and more applications
- Ergonomic and spacious cage design
- Robust, reliable and easy to maintain

STANDARD FEATURES

- 24 V Electric motor
- 24 V – 240 Ah traction batteries
- 30 Amp battery charger
- Battery charge indicator
- 2 drive speed
- 2 back driving wheels
- 2 front steering wheels
- Non marking tires
- Free wheel device
- Hourmeter
- Horn in cage
- Emergency stop buttons at cage and ground
- 2 Control stations, cage and ground

OPTIONS & ACCESSORIES

- Centralised battery filling
- Flashing beacon
- Safety harness anchor points
- Motion alarm
- 220V line to cage
- Airline to cage

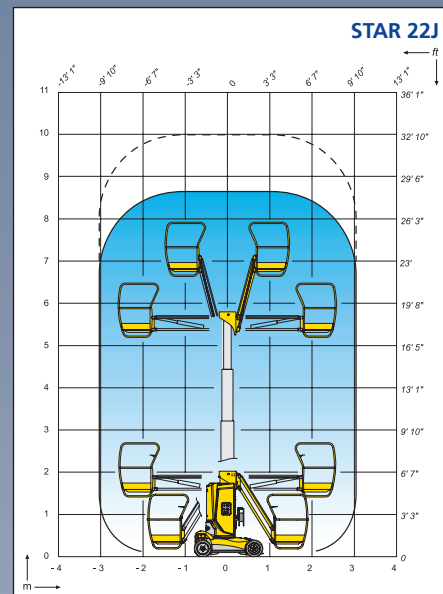
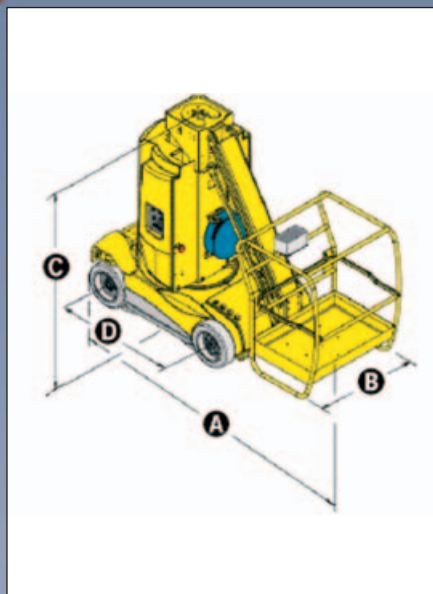

SPECIFICATIONS

	STAR 22J	STAR 26J
Working Height	28ft 2in	32ft 3in
Platform Height	22 ft 2 in	26 ft 3 in
Horizontal outreach	9 ft 10 in	
Platform Capacity	441 lb	
A Length	8 ft 7 in	
B Width	3 ft 3in	3 ft 11in
C Stowed Height	6 ft 6 in	
D Wheelbase	3 ft 11 in	
Ground Clearance	4 in	
Platform size	36 in x 26 in	
Fly jib range of motion	-60° / +80°	
Tailswing	0	
Drive speed	0.43 - 2.8 mph	
Outside turning radius	6 ft 2 in	
Turntable rotation	345°	
Traction batteries	24 V (2 x 12 V) / 240 Ah	
Gradeability	23%	
Tilt alarm	3°	
Non marking tires	16" x 5" x 10,5"	
Weight	5,987 lb	6338 lb

ANSI/SIA A92.6 and CSA/B354.4 Standards Compliance



HAULOTTE US INC • 7135 Standard drive - Hanover - MD21076 - USA
Tel : +1 410 7124403 • Fax : +1 410 7124419 • Toll free : +1 877-HAULOTTE • e-mail: sales@us.haulotte.com