

# V E R T I C A L M A S T

## STAR 13



- Compact and easy to drive
- 5ft 4 in stowed height
- 30 in width
- Electric and proportional controls



# STAR 13

# Vertical mast

## The Haulotte® advantages

- Ideally suited for maintenance works
- Electric drive possible at full height
- 5ft 4in stowed height allowing passage through standard doors and lifts
- 30 in width, very tight turning radius offering high driveability in the most congested areas
- Proportional controls allowing soft and very progressive driving
- 3.1 mph maximum drive speed
- Low weight allowing high autonomy
- Robust, reliable and easy to maintain

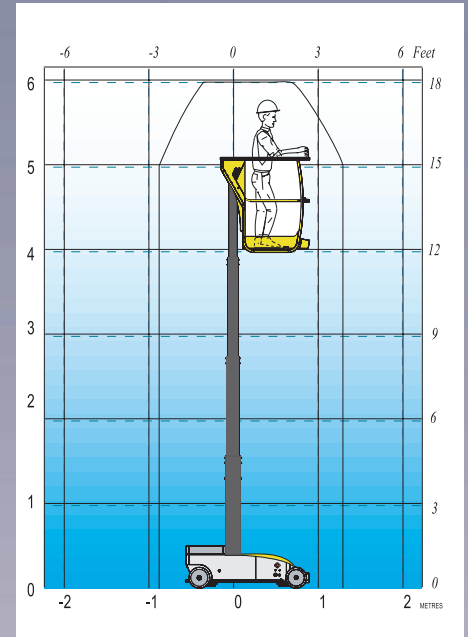
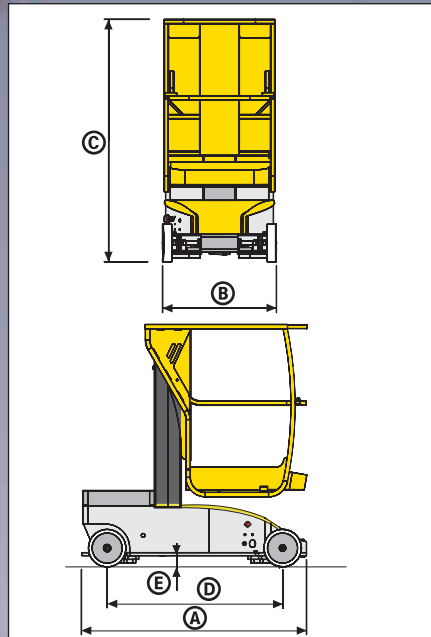

## STANDARD FEATURES

- 24 V electric engine continuous
- 24 V - 180 AH semi-traction batteries
- 30 Amp charger
- Batteries load indicator
- 2 drive speeds
- 2 front drive and steer wheel
- Non marking tires
- Free wheeling device
- Hourmeter
- Horn in cage
- Emergency stop
- Towing hooks
- Detachable control box with outlets in the basket or on the chassis

## OPTIONS & ACCESSORIES

- Batteries centralised filling
- Flashing light
- Working light
- Motion for all-movements alarm
- 110 V line to cage
- Airline to cage

## SPECIFICATIONS

Working height	19 ft 1 in
Platform height	13 ft 1 in
Driveable up to	13 ft 1 in
Maximum capacity	397 lb
<b>A</b> Stowed length	4 ft 11 in
<b>B</b> Overall width	30 in
<b>C</b> Stowed height	5 ft 4 in
<b>D</b> Wheelbase	3 ft 10 in
<b>E</b> Ground clearance	2.75 in
Platform size	31 in x 27 in
Tailswing	0
Drive speed proportional	0.9 / 3.1 mph
Lift speed	17 / 30 sec.
Outside turning radius	3 ft 3 in
Semi-traction batteries	24 V / 180 Ah
Maximum gradeability	22 %
Non marking tires	250 x 60
Hydraulic tank	1.84 gal.
Weight	1,763 lb

ANSI/SIA A92.6 and CSA/B354-4 Standards Compliance



**Haulotte**   
GROUP

HAULOTTE US INC • 7135 Standard drive - Hanover - MD21076 - USA  
Tel : +1 410 7124403 • Fax : +1 410 7124419 • Toll free : +1 877-HAULOTTE • e-mail : sales@us.haulotte.com

Haulotte Group - La Péronnière - BP 9 - 42152 l'Horme - France • Tél : +33 (0)4 77 29 24 24 - Fax : +33 (0)4 77 29 43 95  
e.mail - haulotte@haulotte.com • web : http://www.haulotte.com