

# P U S H   A R O U N D

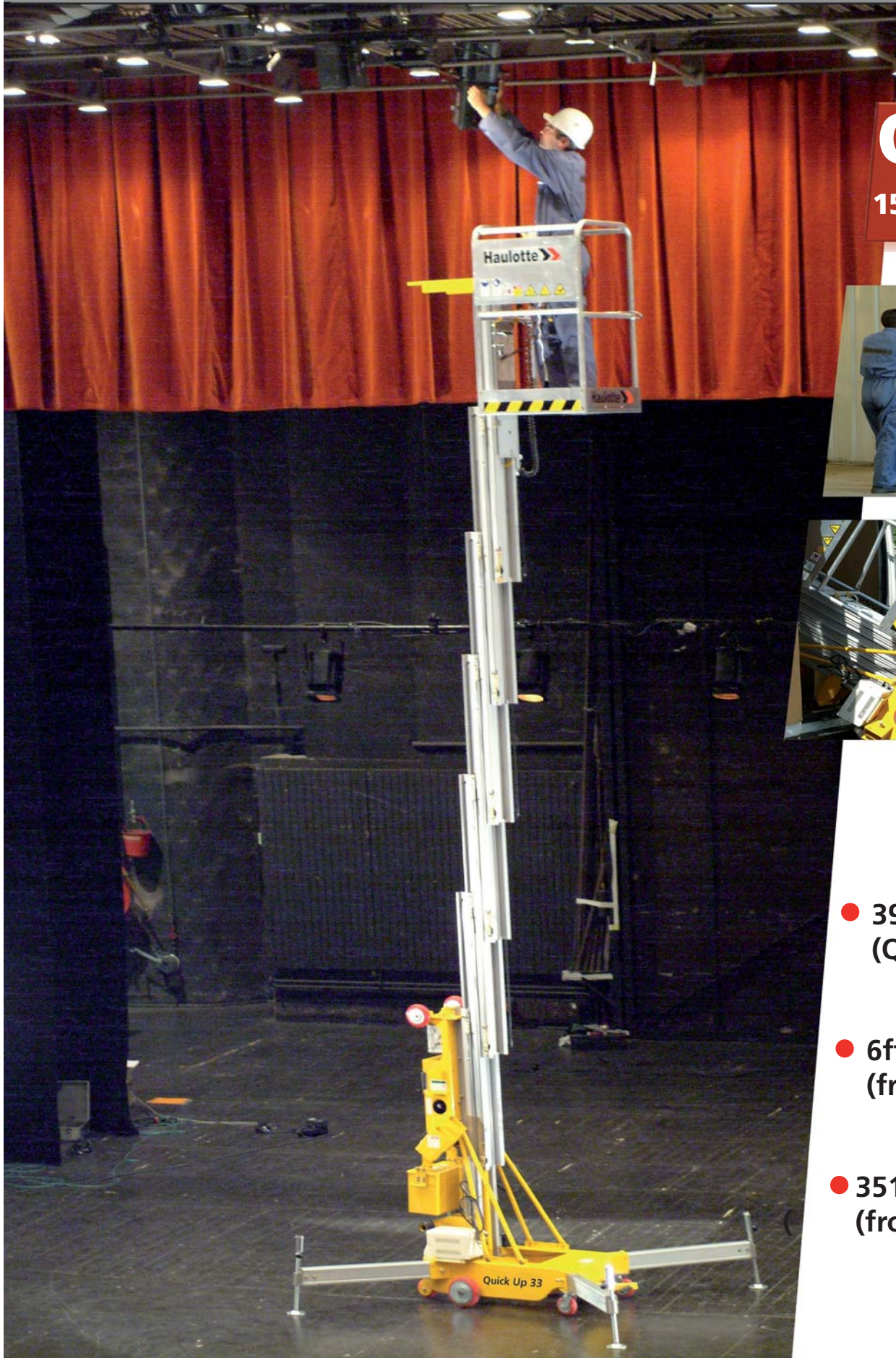

## Quick up

15/20/24/29/33/35/40



- 39ft 1 in platform height (Quick Up 40)
- 6ft 6 in stowed height (from Quick Up 20 to 33)
- 351 lb Platform capacity (from Quick Up 20 to 33)



**Haulotte**   
GROUP

# Quick up

15/20/24/29/33/35/40

# Push around

## The Haulotte® advantages

- Easy to install and set up
- Easy "stand up" access through flip up top rail into basket
- Only one man for loading and unloading
- The Quick Up compact dimensions allows access through standard doorways
- The Quick Up low weight allows works on fragile grounds
- Cage and mast in aluminium

## STANDARD FEATURES

- Push button controls
- 220V A/C power to platform
- AC or DC power available
- Emergency stop button
- Outriggers indicator lights
- Manual emergency valve

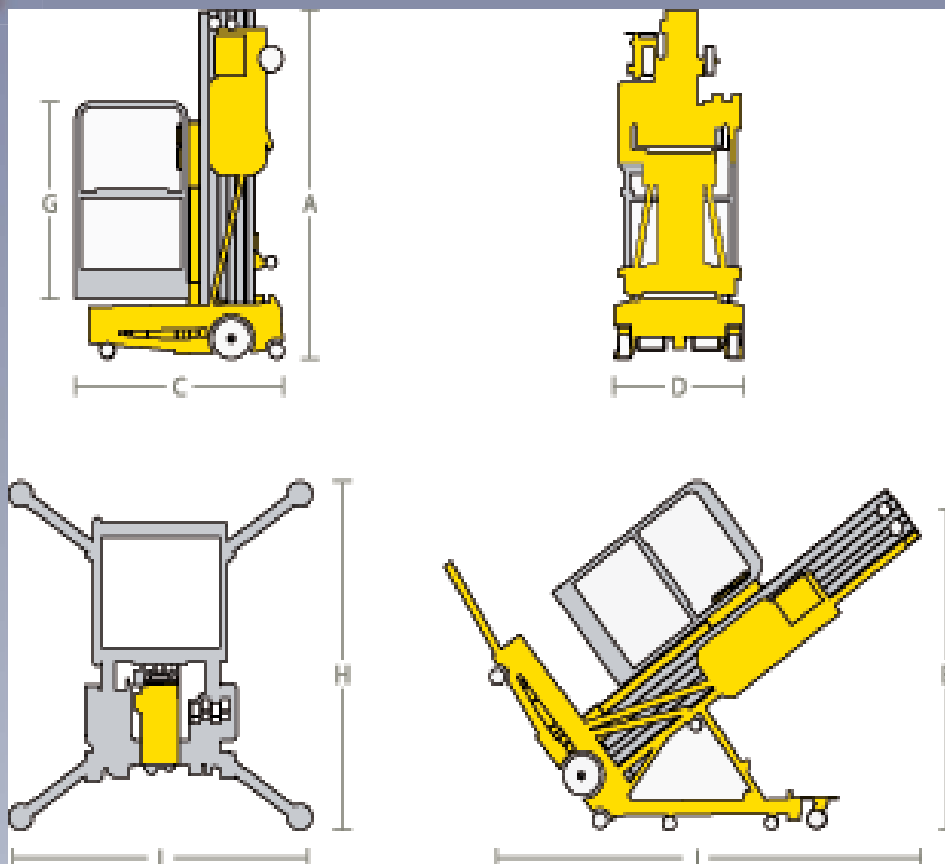

## SPECIFICATIONS

	Quick Up 15	Quick Up 20	Quick Up 24	Quick Up 29	Quick Up 33	Quick Up 35	Quick Up 40
Working Height	21ft 4in	25ft 11in	30ft 6in	34ft 7 in	39ft 4in	42ft 0 in	45ft 7in
Platform height	14ft 9in	19ft 4in	23ft 11in	28ft 7in	32ft 10in	35ft 5in	39ft 1in
Platform capacity	351 lb						300 lb
Max Platform size	26 inx27 in						
<b>A</b> - Stowed height	6ft 6in					9ft 1in	
<b>C</b> - Stowed length	4ft 0 in	4ft 2in	4ft 5in	4ft 7in	4ft 7in	4ft 5in	4ft 7in
<b>D</b> - Stowed width	2ft 5in					2ft 7in	
<b>G</b> - Guardrails height	3ft 9in						
<b>I x H</b> - Outriggers footprint	55 inx67 in			1,6x1,9	1,81x2,1	1,81x2,1	2,02x2,32
<b>J x B</b> - Tilt bar	83 inx69 in					111 inx78 in	
AC version	Energy	110/220V					
	Weight	673 lb	719 lb	765 lb	811 lb	858 lb	1017 lb
Batteries version	Energy	12 V					
	Weight	763 lb	807 lb	853 lb	900 lb	946 lb	1105 lb

ANSI/SIA A92.3 and CSA/B354-1 Standards Compliance



2420328860 - Ed.12/2006 - Products specifications are subject to change without notice - non contractual document.

### HAULOTTE US INC.

7135 STANDARD DRIVE HANOVER MD 21076 - USA  
 TEL: +1 410 712 4403 FAX: +1 410 712 4419  
 TOLL FREE: 877-HAULOTTE SUPPORT TOLL FREE: 877-HAULOT-S

Web : [www.haulotte-usa.com](http://www.haulotte-usa.com)  
 E mail : [sales@us.haulotte.com](mailto:sales@us.haulotte.com)

### HAULOTTE US INC.

1925 SHILOH ROAD BUILDING 3, SUITE 400  
 KENNESAW, GA 30144  
 TEL: +1-770-975-1111  
 TOLL FREE: +1-877-795-8111-886-795-8111